

Series of Cold welding machine

SWM-J1 Portable Welding Machine

一. Advantage:

| | |
|--|---|
|  | <ol style="list-style-type: none"> 1. Welding Results is perfect 2. Pulling force test: constant to the joints. 3. The resistance test: Resistance value is not greater than that of the original wire. 4. changes of wire diameter: In order to meet the user's need for welding the wires of various materials our company can provide the cold welding dies having various kind if inner grooves for users |
|--|---|

二. How to choose the model

2.1 Single wire

| Item | Model | Copper wire size | Aluminum wire size | Dimension | N.W | Die |
|----------------|-----------|------------------|--------------------|---------------|-------|-----|
| | | (mm) | (mm) | (mm) | | |
| J1 Portable | SWM-J1 | Φ0.10~0.50 | Φ0.10~0.50 | 160x50x160 | 1Kg | J1 |
| J1 | SWJ1T | Φ0.10~0.55 | Φ0.10~0.60 | 260x90x220mm | 3Kg | J1 |
| J2 | SWM-2T | Φ0.30- Φ1.20 | Φ0.30-Φ1.40 | 220x130x200 | 9.5Kg | J2 |
| J3 | SWM-3T | Φ1.00- Φ3.25 | Φ1.00-Φ5.00 | 300x180x300 | 36Kg | J3 |
| J4TY | SWM- J4TY | Φ1.00- Φ4.00 | Φ1.00-Φ6.00 | 550x550x920 | 130Kg | J4 |
| J5TY | SWM-J5TY | Φ4.00- Φ8.00 | Φ4.00- 14.00 | 1190x570x1100 | 650Kg | |

2.2 Multi Wire

| Item | Model | Wire size | Dimension | N.W | Die |
|------|---------|--|-----------------|-------|---------------------|
| 1 | SWMHD-1 | 0.5 mm ² -10mm ² | 600x500x1200mm | 45KG | Quartz Glass Sleeve |
| 2 | SWMHD-2 | 16mm ² -120mm ² | 1260*660*1200mm | 150KG | Quartz Glass Sleeve |

三、Quotation

| | |
|--|--|
| CUSTOMER CODE: | QUOTION NO: DATE: |
| CUSTOMER INFORMATION: TEL: FAX: ATTN: | MANUFACTURE: PAYMENT TERMS:100 TT IN ADVANCE BENEFICIARY: SHANGHAI SHINEWORLD ENGINEERING CO., LTD. ACCOUNT NO.: 450773903470 (USD) BANK NAME: BANK OF CHINA, SHANGHAI DALIAN ROAD SUB-BRANCH BANK ADDRESS:NO. 688, DALIAN ROAD, YANGPU DISTRICT, SHANGHAI, CHINA BANK TEL.: 86-21-33772960 FAX: 86-21-33772962 SWIFT CODE: BKCHCNBJ300 |

| SN | DESCRIPTION | PICTURE | QTY | FOB SHANGHAI UNIT PRICE/USD | FOB SHANGHAI AMOUNT/USD |
|---------------|---------------------------------|---|---------|-----------------------------|-------------------------|
| 1 | SWM-J1 Portable Welding Machine |  | 1.00SET | 700.00 | 700.00 |
| 2 | J1 Dies |  | 1.00SET | 120.00 | 120.00 |
| TOTAL: | | | | | |

REMARK:

1, The detailed specification will be integral part of this quotation.

2, Price basis: Price are for delivery FOB Shanghai, China according to INCOTERMS 2010. And the exchange rate for USD: RMB is 1:6.60. If the exchange rate is changed over 0.5%, the quotation will be adjusted accordingly even in the validity time.

3, Validity of quotation: the quotation is validly within 30 days after issue date.

4, Delivery period: the delivery time is 10 days after receipt of your down payment

5, The quotation is based china standard material and package.

6, All the bank charge is paid by buyer.

Leading the global wire and cable industry with intelligent manufacturing and new materials.

四、SPECIFICATION

SWM-J1 Portable cold welding machine







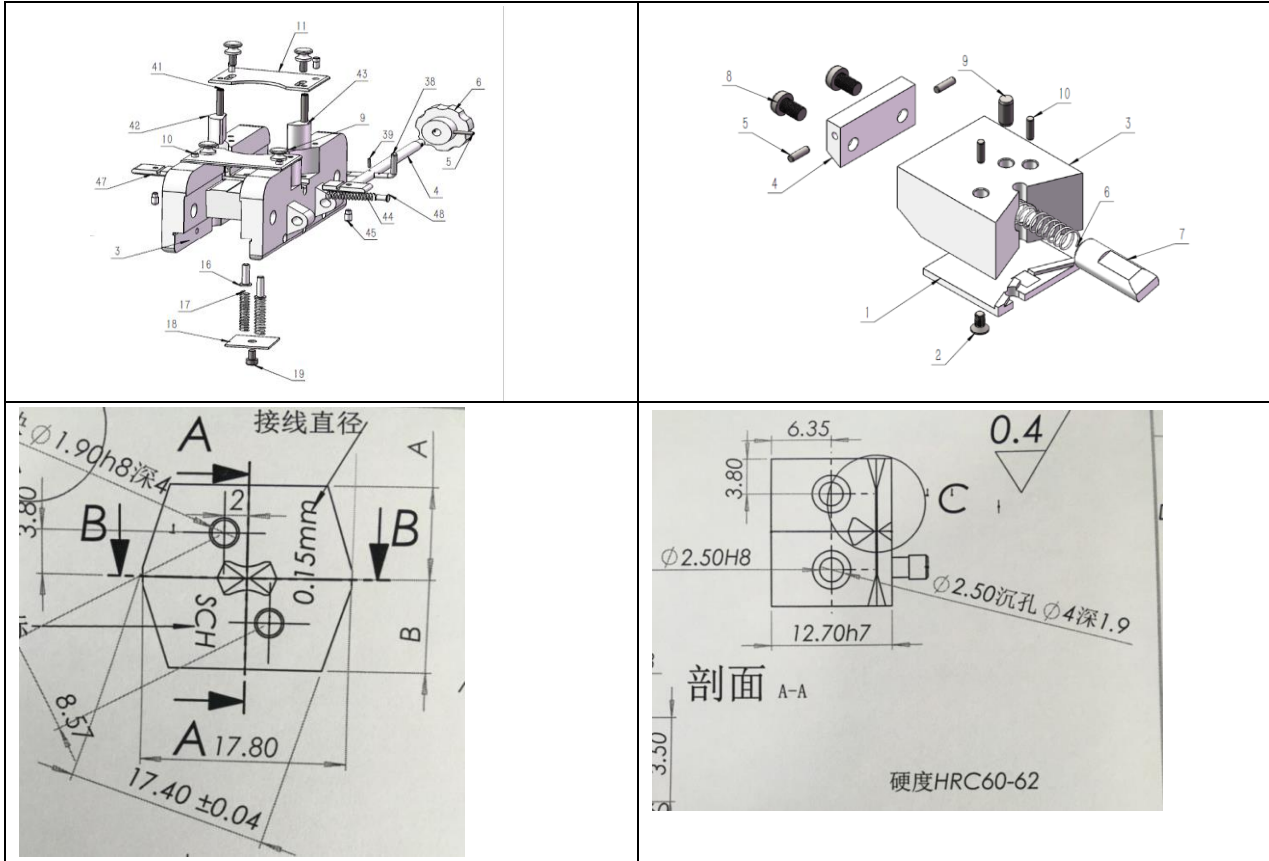
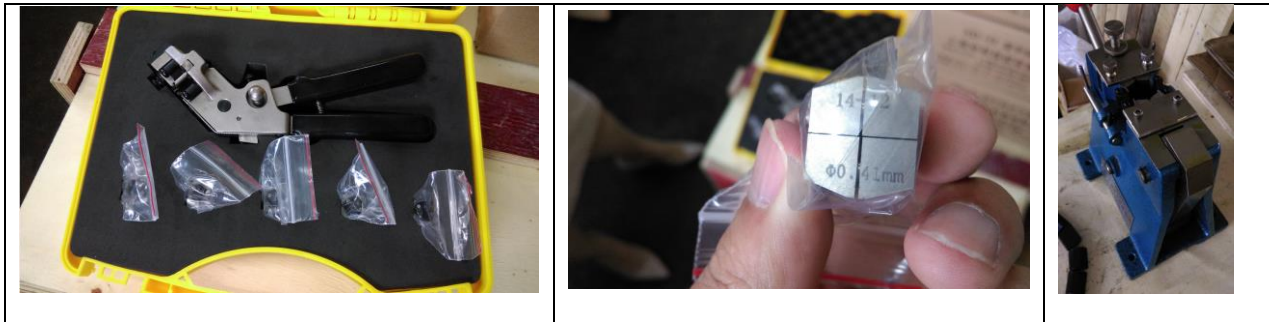







| | |
|---------------|---|
| Product use | Copper, aluminum, gold, silver, nickel, platinum, zinc, tin, tantalum, niobium and other non-ferrous metals and their alloy wires' cold welding. |
| Welding Size | Cu:Φ0.10~0.50mm, Al: Φ0.10~0.50mm, |
| Body material | Casting stainless steel |
| Advantage | Without power supply, safe and reliable, simple operation and welding, after welding the resistance of the material elongation and related physical and chemical indicators won't change. |
| Dimensions | L×W×H 190mm×50mm×60 mm |
| G.W | 1.0Kg |

| | |
|------|----|
| Dies | J1 |
|------|----|

五、ENGINEERING DOCUMENTS

六、SPARE PARTS
七、INSPECTION&PACKING
7.1. INSPECTION PICTURE

7.2. INSPECTION REPORT

| | |
|--|--|
| | |
|--|--|

| Shineworld | | | | Supplier: _____ Signature: Engineer: _____ Date: 2019-11-28 | | |
|------------|-------------|---------------------|---|--|---|------------|
| SN | ITEM | Inspection Standard | Inspection Specification | Inspection result | Photos | Conclusion |
| 1 | cold welder | cold welder | 1 Model: CH-20 (4PCS) - CH-20 (2PCS) 2 QTY: 2PCS | OK |  | OK |
| | | | 1 Model: SQ-10 2 QTY: 2PCS | OK |  | OK |
| 2 | box | box | 1 Size and quantity as per drawing | OK |  | OK |

| Shineworld | | | | Equipment inspection report | | |
|--|-----------------------------|---|--------------------------|--------------------------------------|---|------------|
| Supplier: _____ Signature: _____ Date: 2019-11-28 | | | | Signature: _____ Date: 2019-11-28 | | |
| SN | ITEM | Inspection Standard | Inspection Specification | Inspection result | Photos | Conclusion |
| 1 | J2 cold welding machine | Copper wire: φ0.25-φ1.50mm Al wire: φ0.30-φ1.50mm | OK | OK |  | OK |
| 2 | J3 cold welding machine | Copper wire: φ0.30-φ1.50mm Al wire: φ0.30-φ1.50mm | OK | OK |  | OK |
| 3 | welding die | 0.80 | 2 PCS | OK |  | OK |
| 4 | 2 sets cold welding machine | welding die: 1.20 | 2 PCS | OK |  | OK |
| 5 | welding die | 1.50 | 2 PCS | OK |  | OK |
| 6 | 4 PCS welding die | 2.80 | 2 PCS | OK |  | OK |
| 7 | | | | | | |
| 8 | | | | | | |
| 9 | | | | | | |
| 10 | | | | | | |
| 11 | box 1 | 180mm*230mm*420mm | 1PKG | |  | |
| 12 | box 2 | 180mm*430mm*470mm | 4PKGS | |  | |
| 13 | | | | | | |
| 14 | Package | | | |  | |
| 15 | | | | | | |
| 16 | | | | | | |
| 17 | Final report | The machine reach the PI requirements and is ready for shipment | | | | |

7.3. PACKIGN

7.3.1.PACKING DETAILS

| SN | Name | HS code | Dimension(mm) | | | Unit V(M ³) | Unit net Weight | Unit gross Weight | PKG NO |
|----|--------------------------------------|--|---------------|----|----|-------------------------|-----------------|-------------------|--------|
| | | | | | | | | | |
| 1 | SWM-J1 Portable cold welding machine | 8468800000 | 190 | 50 | 60 | 0.01 | 1.0 | 1.0 | 1 |
| | 申报要素 | 1 品名: 冷焊机 2 用途: 用于电缆生产线 3 加工方式: 用挤压的方式连接金属丝 4 品牌: 无; 5 型号: 无 | | | | | | | |

7.3.2.PACKIGN PICTURE



SWMJ1T table type Welding Machine

一. Advantage:

| | |
|--|--|
|  | <p>2. Welding Results is perfect</p> <p>2. Pulling force test: constant to the joints.</p> <p>3. The resistance test: Resistance value is not greater than that of the original wire.</p> <p>4. changes of wire diameter: In order to meet the user's need for welding the wires of various materials our company can provide the cold welding dies having various kind if inner grooves for users</p> |
|--|--|

二. How to choose the model

2.1 Single wire

| Item | Model | Copper wire size | Aluminum wire size | Dimension | N.W | Die |
|-------------|----------|------------------|--------------------|---------------|-------|-----|
| | | (mm) | (mm) | (mm) | | |
| J1 Portable | SWM-J1 | Φ0.10~0.50 | Φ0.10~0.50 | 160x50x160 | 1Kg | J1 |
| J1 | SWMJ1T | Φ0.10~0.55 | Φ0.10~0.60 | 260x90x220mm | 3Kg | J1 |
| J2 | SWM-2T | Φ0.30-Φ1.20 | Φ0.30-Φ1.40 | 220x130x200 | 9.5Kg | J2 |
| J3 | SWM-3T | Φ1.00-Φ3.25 | Φ1.00-Φ5.00 | 300x180x300 | 36Kg | J3 |
| J4TY | SWM-4T | Φ1.00-Φ4.00 | Φ1.00-Φ6.00 | 550x550x920 | 130Kg | J4 |
| J5TY | SWM-J5TY | Φ4.00-Φ8.00 | Φ4.00- 14.00 | 1190x570x1100 | 650Kg | |

2.2 Multi Wire

| Item | Model | Wire size | Dimension | N.W | Die |
|------|---------|--|-----------------|-------|---------------------------|
| 1 | SWMHD-1 | 0.5 mm ² -10mm ² | 600x500x1200mm | 45KG | Quartz Glass Sleeve |
| 2 | SWMHD-2 | 16mm ² -120mm ² | 1260*660*1200mm | 150KG | Quartz Glass Sleeve |

三、Quotation

| | |
|--|--|
| CUSTOMER CODE: | QUOTION NO: DATE: |
| CUSTOMER INFORMATION: TEL: FAX: ATTN: | MANUFACTURE: PAYMENT TERMS:100 TT IN ADVANCE BENEFICIARY: SHANGHAI SHINEWORLD ENGINEERING CO., LTD. ACCOUNT NO.: 450773903470 (USD) BANK NAME: BANK OF CHINA, SHANGHAI DALIAN ROAD SUB-BRANCH BANK ADDRESS:NO. 688, DALIAN ROAD, YANGPU DISTRICT, SHANGHAI, CHINA BANK TEL.: 86-21-33772960 FAX: 86-21-33772962 SWIFT CODE: BKCHCNBJ300 |

| SN | DESCRIPTION | PICTURE | QTY | FOB SHANGHAI UNIT PRICE/USD | FOB SHANGHAI AMOUNT/USD |
|---------------|----------------------------------|---|---------|-----------------------------|-------------------------|
| 1 | SWJ1T table type Welding Machine |  | 1.00SET | 600.00 | 600.00 |
| 2 | J1 Dies |  | 1.00SET | 120.00 | 120.00 |
| TOTAL: | | | | | |

REMARK:

1, The detailed specification will be integral part of this quotation.

2, Price basis: Price are for delivery FOB Shanghai, China according to INCOTERMS 2010. And the exchange rate for USD: RMB is 1:6.60. If the exchange rate is changed over 0.5%, the quotation will be adjusted accordingly even in the validity time.

3, Validity of quotation: the quotation is validly within 30 days after issue date.

4, Delivery period: the delivery time is 10 days after receipt of your down payment

5, the quotation is based china standard material and package.

6, All the bank charge is paid by buyer.

Leading the global wire and cable industry with intelligent manufacturing and new materials.

四、SPECIFICATION

SWJ1T table type cold welding machine



| | |
|-------------------|--|
| Product use | Copper, aluminum, gold, silver, nickel, platinum, zinc, tin, tantalum, niobium and other non-ferrous metals and their alloy wires' cold welding. |
| Welding Size | Cu: 0.1 mm-0.55 mm, Al: 0.1mm-0.60 mm, |
| Products material | The body made for Precision casting steel |

| | |
|------------|--|
| Advantage | Without power supply, safe and reliable, simple operation and welding, after welding the resistance of the material material elongation and related physical and chemical indicators won't change. |
| Dimensions | LxWxH 260x90x220mm |
| G.W | 3.0Kgs |
| Dies | J1 |

五、SPARE PARTS

六、ENGINEERING DOCUMENTS

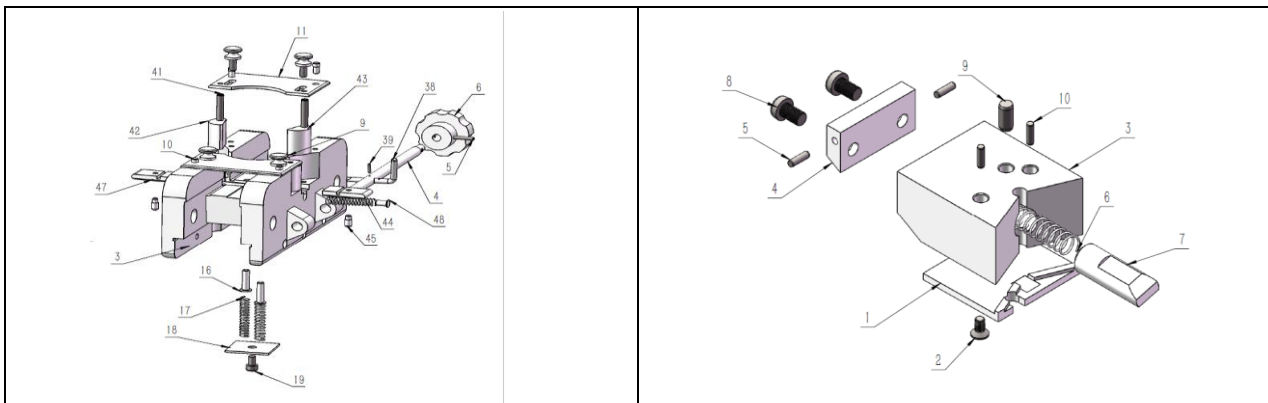



















七、INSPECTION&PACKING

7.1.INSPECTION PICTURE



7.2. INSPECTION REPORT

| Inspection Description | | Inspection result | Photo | Conclusion |
|------------------------|-------------|-------------------|---|------------|
| 1 | cold welder | OK |  | OK |
| 2 | die | OK |  | OK |

| SN | ITEM | Inspection | Specification | Standard Details | Inspection result | Photo | Conclusion | |
|----|-------------------------|--|---------------|------------------|-------------------|---|------------|--|
| 1 | J2 cold welding machine | Copper wire: φ0.25-φ1.50mm | | | OK |  | OK | |
| 2 | J3 cold welding machine | Copper wire: φ0.25-φ1.50mm | | | OK |  | OK | |
| 3 | welding die | φ3.08 | | 2 PCS | OK |  | OK | |
| 4 | 2 sets cold welding die | 1.20 | | 2 PCS | OK |  | OK | |
| 5 | welding die | 1.50 | | 2 PCS | OK |  | OK | |
| 6 | welding die | 2.80 | | 2 PCS | OK |  | OK | |
| 7 | | | | | |  | | |
| 8 | | | | | |  | | |
| 9 | | | | | |  | | |
| 10 | | | | | |  | | |
| 11 | box 1 | 380mm*230mm*420mm | | 17KG | |  | | |
| 12 | box 2 | 380mm*420mm*470mm | | 47KG | |  | | |
| 13 | Package | | | | |  | | |
| 14 | | | | | |  | | |
| 15 | | | | | |  | | |
| 16 | | | | | |  | | |
| 17 | Final report | The machine reach the PI requirements and is ready to shipment | | | | | | |

7.3. PACKING
7.3.1.PACKING DETAILS

| SN | Name | HS code | Dimension(mm) | | | Unit | Unit net | Unit gross | PKG NO |
|----|----------------------------|---|---------------|----|-----|-------|----------|------------|--------|
| | | | | | | V(M³) | Weight | Weight | |
| 1 | SWJ1T Cold welding machine | 8468800000 | 260 | 90 | 220 | 0.01 | 3.0 | 3.0 | 1 |
| | 申报要素 | 1 品名：冷焊机 2 用途：用于电缆生产线 3 加工方式：用挤压的方式连接金属丝 4 品牌：无； 5 型号：无 | | | | | | | |

PACKIGN PICTURE

SWM-J2T cold welding machine

一. Advantage:

| | |
|--|--|
|  | <p>3. Welding Results is perfect</p> <p>2. Pulling force test: constant to the joints.</p> <p>3. The resistance test: Resistance value is not greater than that of the original wire.</p> <p>4. changes of wire diameter: In order to meet the user's need for welding the wires of various materials our company can provide the cold welding dies having various kind if inner grooves for users</p> |
|--|--|

二. How to choose the model

2.1 Single wire

| Item | Model | Copper wire size | Aluminum wire size | Dimension | N.W | Die |
|-------------|----------|------------------|--------------------|---------------|-------|-----|
| | | (mm) | (mm) | (mm) | | |
| J1 Portable | SWM-J1 | Φ0.10~0.50 | Φ0.10~0.50 | 160x50x160 | 1Kg | J1 |
| J1 | SWMJ1T | Φ0.10~0.55 | Φ0.10~0.60 | 260x90x220mm | 3Kg | J1 |
| J2 | SWM-2T | Φ0.30-Φ1.20 | Φ0.30-Φ1.40 | 220x130x200 | 9.5Kg | J2 |
| J3 | SWM-3T | Φ1.00-Φ3.25 | Φ1.00-Φ5.00 | 300x180x300 | 36Kg | J3 |
| J4TY | SWM-4T | Φ1.00-Φ4.00 | Φ1.00-Φ6.00 | 550x550x920 | 130Kg | J4 |
| J5TY | SWM-J5TY | Φ4.00-Φ8.00 | Φ4.00- 14.00 | 1190x570x1100 | 650Kg | |

2.2 Multi Wire

| Item | Model | Wire size | Dimension | N.W | Die |
|------|---------|--|-----------------|-------|---------------------------|
| 1 | SWMHD-1 | 0.5 mm ² -10mm ² | 600x500x1200mm | 45KG | Quartz Glass Sleeve |
| 2 | SWMHD-2 | 16mm ² -120mm ² | 1260*660*1200mm | 150KG | Quartz Glass Sleeve |

三、Quotation

| | |
|--|--|
| CUSTOMER CODE: | QUOTION NO: DATE: |
| CUSTOMER INFORMATION: TEL: FAX: ATTN: | MANUFACTURE: PAYMENT TERMS:100 TT IN ADVANCE BENEFICIARY: SHANGHAI SHINEWORLD ENGINEERING CO., LTD. ACCOUNT NO.: 450773903470 (USD) BANK NAME: BANK OF CHINA, SHANGHAI DALIAN ROAD SUB-BRANCH BANK ADDRESS:NO. 688, DALIAN ROAD, YANGPU DISTRICT, SHANGHAI, CHINA BANK TEL.: 86-21-33772960 FAX: 86-21-33772962 SWIFT CODE: BKCHCNBJ300 |

| SN | DESCRIPTION | PICTURE | QTY | FOB SHANGHAI UNIT PRICE/USD | FOB SHANGHAI AMOUNT/USD |
|---------------|----------------------------------|---|---------|-----------------------------|-------------------------|
| 1 | SWJ2T table type Welding Machine |  | 1.00SET | 700.00 | 700.00 |
| 2 | J1 Dies |  | 1.00SET | 120.00 | 120.00 |
| TOTAL: | | | | | 820 |

REMARK:

1, The detailed specification will be integral part of this quotation.

2, Price basis: Price are for delivery FOB Shanghai, China according to INCOTERMS 2010. And the exchange rate for USD: RMB is 1:6.60. If the exchange rate is changed over 0.5%, the quotation will be adjusted accordingly even in the validity time.

3, Validity of quotation: the quotation is validly within 30 days after issue date.

4, Delivery period: the delivery time is 10 days after receipt of your down payment

5, the quotation is based china standard material and package.

7, All the bank charge is paid by buyer.

Leading the global wire and cable industry with intelligent manufacturing and new materials.

四、SPECIFICATION

SWJ2T table type cold welding machine



| | |
|-------------------|--|
| Product use | Copper, aluminum, gold, silver, nickel, platinum, zinc, tin, tantalum, niobium and other non-ferrous metals and their alloy wires' cold welding. |
| Welding Size | Cu: $\Phi 0.30\text{-}\Phi 1.20\text{mm}$ Al: $\Phi 0.30\text{-}\Phi 1.40\text{mm}$, |
| Products material | The body made for Precision casting steel |

| | |
|------------|--|
| Advantage | Without power supply, safe and reliable, simple operation and welding, after welding the resistance of the material material elongation and related physical and chemical indicators won't change. |
| Dimensions | L×W×H 220x130x200 |
| G.W | 9.5Kgs |
| Dies | J2 |

五、SPARE PARTS

六、ENGINEERING DOCUMENTS

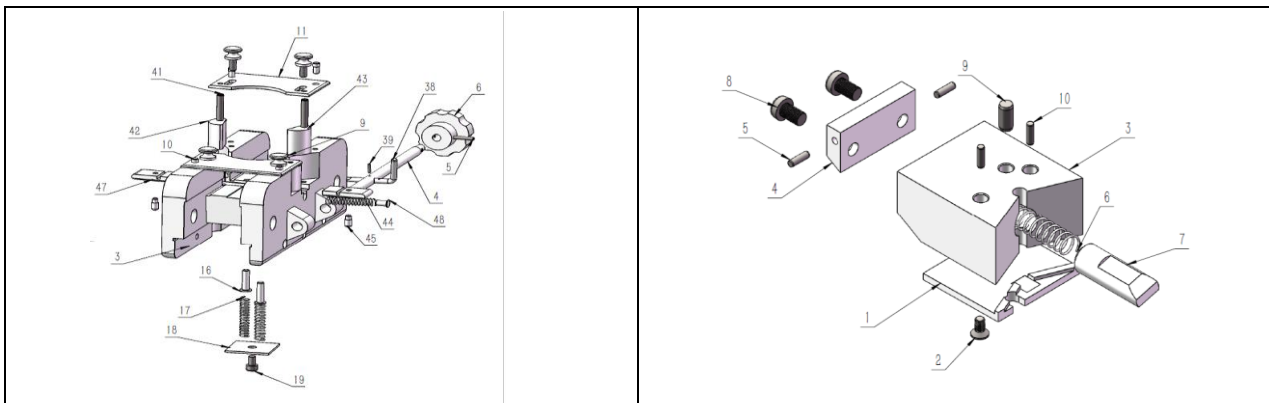







七、INSPECTION&PACKING

7.1.INSPECTION PICTURE



7.2. INSPETION REPORT

|  | | | | Supplier: _____ Signature: Engineer: Fritze Product Name and specification: _____ 2019-11-28 Order No: SWJ2T-1910000 | | |
|---|-------------|-------------|---|--|---|------------|
| Inspection Standard | | Inspection | | | | |
| SN | ITEM | Inspection | Specification | Inspection Result | Photo | Conclusion |
| 1 | cold welder | cold welder | 1 Model: CW20 (APC)-1, CW20, 2 (20T) pieces | OK |  | OK |
| | | | 1 Model: SD-10, 2 (20T) pieces | OK |  | OK |
| 2 | die | die | 1 Size and quantity as per die | OK |  | OK |

|  | | | | Equipment inspection report Supplier: _____ Signature: _____ Product Name: 2 sets cold welding machine Order No: SWJ2T-1910000 Date: 2019-11-28 | | | |
|---|------|-------------------------|----------------------------|---|-------------------|---|------------|
| Inspection Standard | | Inspection | | | | | |
| SN | ITEM | Inspection | Specification | Standard Details | Inspection Result | Photo | Conclusion |
| 1 | | J2 cold welding machine | Copper wire: φ0.25-φ1.50mm | | OK |  | OK |
| 2 | | J3 cold welding machine | Copper wire: φ0.5-φ1.5mm | | OK | | OK |
| 3 | | welding die | φ0.38 | 2 PCS | OK | | OK |
| 4 | | 2 sets cold welding die | 1.20 | 2 PCS | OK | | OK |
| 5 | | welding die | 1.50 | 2 PCS | OK | | OK |
| 6 | | 4PCS welder die | 2.90 | 2 PCS | OK | | OK |
| 7 | | | | | | | |
| 8 | | | | | | | |
| 9 | | | | | | | |
| 10 | | | | | | | |
| 11 | | Box 1 | 280mm*230mm*420mm | 17KG | |  | |
| 12 | | Box 2 | 390mm*430mm*470mm | 47KG | | | |
| 13 | | | | | | | |
| 14 | | | | | | | |
| 15 | | | | | | | |
| 16 | | | | | | | |
| 17 | | | | | | | |
| The machine reach the FT requirements and is ready to shipment | | | | | | | |

7.3. PACKING

7.3.1. PACKING DETAILS

| SN | Name | HS code | Dimension(mm) | | | Unit | Unit net | Unit gross | PKG NO |
|----|----------------------------|--|---------------|-----|-----|--------------------|----------|------------|--------|
| | | | | | | V(M ³) | Weight | Weight | |
| 1 | SWJ2T Cold welding machine | 8468800000 | 220 | 130 | 200 | 0.01 | 9.5 | 9.5 | 1 |
| | 申报要素 | 1 品名: 冷焊机 2 用途: 用于电缆生产线 3 加工方式: 用挤压的方式连接金属丝 4 品牌: 无; 5 型号: 无 | | | | | | | |

PACKIGN PITURE



SWM-J3T cold welding machine

一. Advantage:

| | |
|--|--|
|  | <ol style="list-style-type: none"> 4. Welding Results is perfect 2. Pulling force test: constant to the joints. 3. The resistance test: Resistance value is not greater than that of the original wire. 4.changes of wire diameter: In order to meet the user's need for welding the wires of various materials our company can provide the cold welding dies having various kind if inner grooves for users |
|--|--|

二. How to choose the model

2.1 Single wire

| Item | Model | Copper wire size | Aluminum wire size | Dimension | N.W | Die |
|-------------|----------|------------------|--------------------|---------------|-------|-----|
| | | (mm) | (mm) | (mm) | | |
| J1 Portable | SWM-J1 | Φ0.10~0.50 | Φ0.10~0.50 | 160x50x160 | 1Kg | J1 |
| J1 | SWMJ1T | Φ0.10~0.55 | Φ0.10~0.60 | 260x90x220mm | 3Kg | J1 |
| J2 | SWM-2T | Φ0.30-Φ1.20 | Φ0.30-Φ1.40 | 220x130x200 | 9.5Kg | J2 |
| J3 | SWM-3T | Φ1.00-Φ3.25 | Φ1.00-Φ5.00 | 300x180x300 | 36Kg | J3 |
| J4TY | SWM-4T | Φ1.00-Φ4.00 | Φ1.00-Φ6.00 | 550x550x920 | 130Kg | J4 |
| J5TY | SWM-J5TY | Φ4.00-Φ8.00 | Φ4.00- 14.00 | 1190x570x1100 | 650Kg | |

2.2 Multi Wire

| Item | Model | Wire size | Dimension | N.W | Die |
|------|---------|--|-----------------|-------|---------------------|
| 1 | SWMHD-1 | 0.5 mm ² -10mm ² | 600x500x1200mm | 45KG | Quartz Glass Sleeve |
| 2 | SWMHD-2 | 16mm ² -120mm ² | 1260*660*1200mm | 150KG | Quartz Glass Sleeve |

三、Quotation

| CUSTOMER CODE: | | QUOTON NO: | | | |
|-----------------------|----------------------------------|---|---------|-----------------------------|-------------------------|
| | | DATE: | | | |
| CUSTOMER INFORMATION: | | MANUFACTURE: | | | |
| TEL: | | PAYMENT TERMS:100 TT IN ADVANCE | | | |
| FAX: | | BENEFICIARY: SHANGHAI SHINEWORLD ENGINEERING CO., LTD. | | | |
| ATTN: | | ACCOUNT NO.: 450773903470 (USD) | | | |
| | | BANK NAME: BANK OF CHINA, SHANGHAI DALIAN ROAD SUB-BRANCH | | | |
| | | BANK ADDRESS:NO. 688, DALIAN ROAD, YANGPU DISTRICT, SHANGHAI, CHINA | | | |
| | | BANK TEL.: 86-21-33772960 | | | |
| | | FAX: 86-21-33772962 SWIFT CODE: BKCHCNBJ300 | | | |
| SN | DESCRIPTION | PICTURE | QTY | FOB SHANGHAI UNIT PRICE/USD | FOB SHANGHAI AMOUNT/USD |
| 1 | SWJ3T table type Welding Machine |  | 1.00SET | 700.00 | 700.00 |
| 2 | J1 Dies |  | 1.00SET | 120.00 | 120.00 |
| TOTAL: | | | | | 820.00 |

REMARK:

- 1, The detailed specification will be integral part of this quotation.
- 2, Price basis: Price are for delivery FOB Shanghai, China according to INCOTERMS 2010. And the exchange rate for USD: RMB is 1:6.60. If the exchange rate is changed over 0.5%, the quotation will be adjusted accordingly even in the validity time.
- 3, Validity of quotation: the quotation is validly within 30 days after issue date.
- 4, Delivery period: the delivery time is 10 days after receipt of your down payment
- 5, the quotation is based china standard material and package.
- 8, All the bank charge is paid by buyer.

Leading the global wire and cable industry with intelligent manufacturing and new materials.

四、SPECIFICATION

SWJ3T table type cold welding machine



| | |
|-------------------|--|
| Product use | Copper, aluminum, gold, silver, nickel, platinum, zinc, tin, tantalum, niobium and other non-ferrous metals and their alloy wires' cold welding. |
| Welding Size | Cu: $\Phi 1.00\text{-}\Phi 3.25\text{mm}$ Al: $\Phi 1.00\text{-}\Phi 5.00\text{mm}$, |
| Products material | The body made for Precision casting steel |
| Advantage | Without power supply, safe and reliable, simple operation and welding, after welding the resistance of the material material elongation and related physical and chemical indicators won't change. |
| Dimensions L*W*H | 300*180*300 |

| | |
|------|--------|
| G.W | 36 Kgs |
| Dies | J3 |

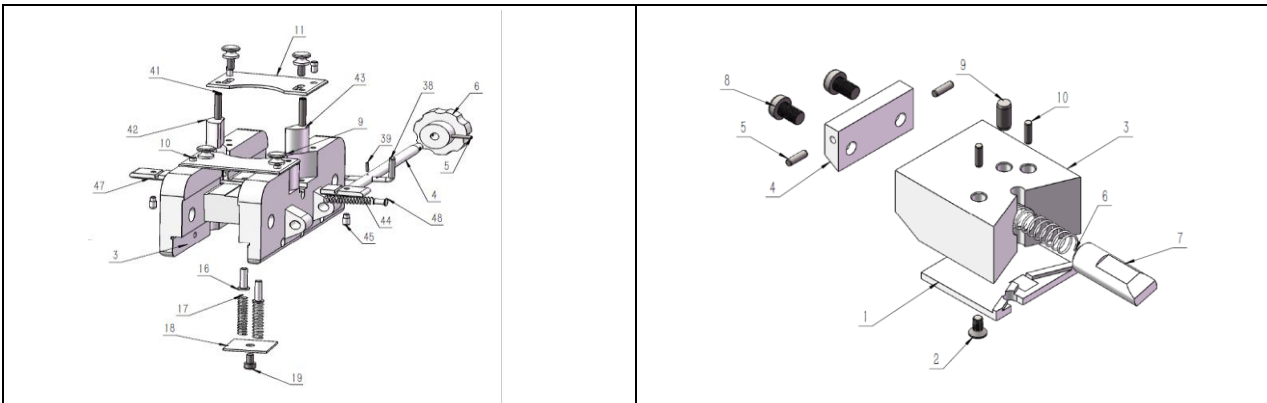
五、 SPARE PARTS
六、 ENGINEERING DOCUMENTS

七、 INSPECTION&PACKING
7.1.INSPECTION PICTURE

7.2. INSPETION REPORT

| | |
|--|--|
| | |
|--|--|

| Shineworld | | | | Supplier: _____ Signature/Engineer/Date: _____ | |
|--------------------------------|-------------|---|-------------------|---|------------|
| Product Name: _____ | | | | Date: 2019-11-28 | |
| Order No: SHINWORLD20191128028 | | | | | |
| SN | ITEM | Inspection Standard | Inspection result | Photos | Conclusion |
| 1 | cold welder | 1 Model: CH-25 (4PCS) - CH-25 (2PCS) 2 QTY: 2PCS | OK |  | OK |
| | cold welder | 1 Model: SO-10 2 QTY: 2PCS | OK |  | OK |
| 2 | die | 1 Size and quantity as list sheet | OK |  | OK |

| Shineworld | | | | Equipment inspection report | |
|--|-------------------------|---|-------------------|---|------------|
| Supplier: _____ Signature/Engineer/Date: _____ | | | | Date: 2019-11-28 | |
| Product Name: _____ | | | | Date: 2019-11-28 | |
| Order No: SHINWORLD20191128028 | | | | | |
| SN | ITEM | Inspection Standard | Inspection result | Photos | Conclusion |
| 1 | J2 cold welding machine | Copper wire: φ0.25-φ1.50mm Al wire: φ0.30-φ1.80mm | OK |  | OK |
| 2 | J3 cold welding machine | Copper wire: φ0.3-φ1.80mm Al wire: φ0.30-φ1.80mm | OK |  | OK |
| 3 | welding die | 0.80 | 2 PCS OK |  | OK |
| 4 | welding die | 1.20 | 2 PCS OK |  | OK |
| 5 | welding die | 1.50 | 2 PCS OK |  | OK |
| 6 | welding die | 2.00 | 2 PCS OK |  | OK |
| 7 | | | | | |
| 8 | | | | | |
| 9 | | | | | |
| 10 | | | | | |
| 11 | box 1 | 180mm*230mm*420mm | 17KG |  | |
| 12 | box 2 | 180mm*430mm*470mm | 47KG |  | |
| 13 | | | | | |
| 14 | Package | | | | |
| 15 | | | | | |
| 16 | | | | | |
| 17 | Final report | The machine reach the PI requirements and is ready for shipment | | | |

7.3. PACKING

7.3.1. PACKING DETAILS

| SN | Name | HS code | Dimension(mm) | | | Unit | Unit net | Unit gross | PKG NO |
|----|----------------------------|---|---------------|-----|-----|--------------------|----------|------------|--------|
| | | | | | | V(M ³) | Weight | Weight | |
| 1 | SWJ3T Cold welding machine | 8468800000 | 300 | 180 | 300 | 0.01 | 36 | 36 | 1 |
| | 申报要素 | 1 品名：冷焊机 2 用途：用于电缆生产线 3 加工方式：用挤压的方式连接金属丝 4 品牌：无； 5 型号：无 | | | | | | | |

7.3.2. PACKING PICTURE



SWM-J4T cold welding machine

一. Advantage:

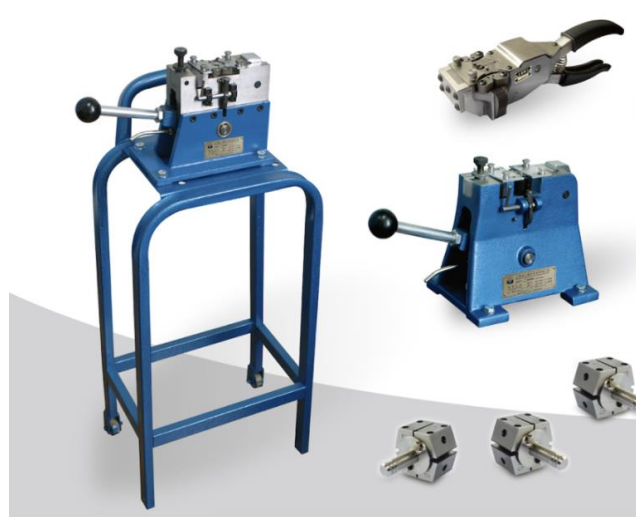
| | |
|---|---|
|  | <ol style="list-style-type: none"> 1. Welding Results is perfect 2. Pulling force test: constant to the joints. 3. The resistance test: Resistance value is not greater than that of the original wire. 4. changes of wire diameter: In order to meet the user's need for welding the wires of various materials our company can provide the cold welding dies having various kind if inner grooves for users |
|---|---|

二. How to choose the model

2.1 Single wire

| Item | Model | Copper wire size | Aluminum wire size | Dimension | N.W | Die |
|-------------|--------|------------------|--------------------|--------------|-----|-----|
| | | (mm) | (mm) | (mm) | | |
| J1 Portable | SWM-J1 | Φ0.10~0.50 | Φ0.10~0.50 | 160x50x160 | 1Kg | J1 |
| J1 | SWMJ1T | Φ0.10~0.55 | Φ0.10~0.60 | 260x90x220mm | 3Kg | J1 |

| | | | | | | |
|------|----------|-------------|--------------|---------------|-------|----|
| J2 | SWM-2T | Φ0.30-Φ1.20 | Φ0.30-Φ1.40 | 220x130x200 | 9.5Kg | J2 |
| J3 | SWM-3T | Φ1.00-Φ3.25 | Φ1.00-Φ5.00 | 300x180x300 | 36Kg | J3 |
| J4TY | SWM-4T | Φ1.00-Φ4.00 | Φ1.00-Φ6.00 | 550x550x920 | 130Kg | J4 |
| J5TY | SWM-J5TY | Φ4.00-Φ8.00 | Φ4.00- 14.00 | 1190x570x1100 | 650Kg | |

2.2 Multi Wire

| Item | Model | Wire size | Dimension | N.W | Die |
|------|---------|--|-----------------|-------|---------------------------|
| 1 | SWMHD-1 | 0.5 mm ² -10mm ² | 600x500x1200mm | 45KG | Quartz Glass Sleeve |
| 2 | SWMHD-2 | 16mm ² -120mm ² | 1260*660*1200mm | 150KG | Quartz Glass Sleeve |

三、Quotation

| CUSTOMER CODE: | | QUOTION NO: | | | |
|-----------------------|-------------|---|-----|-----------------------------|-------------------------|
| | | DATE: | | | |
| CUSTOMER INFORMATION: | | MANUFACTURE: | | | |
| | | PAYMENT TERMS:100 TT IN ADVANCE | | | |
| | | BENEFICIARY: SHANGHAI SHINEWORLD ENGINEERING CO., LTD. | | | |
| | | ACCOUNT NO.: 450773903470 (USD) | | | |
| TEL: | | BANK NAME: BANK OF CHINA, SHANGHAI DALIAN ROAD SUB-BRANCH | | | |
| FAX: | | BANK ADDRESS:NO. 688, DALIAN ROAD, YANGPU DISTRICT, SHANGHAI, CHINA | | | |
| ATTN: | | BANK TEL.: 86-21-33772960 | | | |
| | | FAX: 86-21-33772962 SWIFT CODE: BKCHCNBJ300 | | | |
| SN | DESCRIPTION | PICTURE | QTY | FOB SHANGHAI UNIT PRICE/USD | FOB SHANGHAI AMOUNT/USD |

| | | | | | |
|---|----------------------------------|---|---------|---------------|--|
| 1 | SWJ3T table type Welding Machine |  | 1.00SET | 700.00 | |
| 2 | J1 Dies |  | 1.00SET | 120.00 | |
| | | | | TOTAL: | |

REMARK:

- 1, The detailed specification will be integral part of this quotation.
- 2, Price basis: Price are for delivery FOB Shanghai, China according to INCOTERMS 2010. And the exchange rate for USD: RMB is 1:6.60. If the exchange rate is changed over 0.5%, the quotation will be adjusted accordingly even in the validity time.
- 3, Validity of quotation: the quotation is validly within 30 days after issue date.
- 4, Delivery period: the delivery time is 10 days after receipt of your down payment
- 5, the quotation is based china standard material and package.
- 9, All the bank charge is paid by buyer.

Leading the global wire and cable industry with intelligent manufacturing and new materials.

四、SPECIFICATION

SWJ4T table type cold welding machine



| | |
|-------------------|--|
| Product use | Copper, aluminum, gold, silver, nickel, platinum, zinc, tin, tantalum, niobium and other non-ferrous metals and their alloy wires' cold welding. |
| Welding Size | Cu: $\Phi 1.00\text{-}\Phi 4.00\text{mm}$ Al: $\Phi 1.00\text{-}\Phi 6.00\text{mm}$ |
| Products material | The body made for Precision casting steel |
| Advantage | Without power supply, safe and reliable, simple operation and welding, after welding the resistance of the material material elongation and related physical and chemical indicators won't change. |
| Dimensions | LxWxH 550x550x920 |
| G.W | 130 Kgs |
| Dies | J4 |

五、 SPARE PARTS

六、 ENGINEERING DOCUMENTS

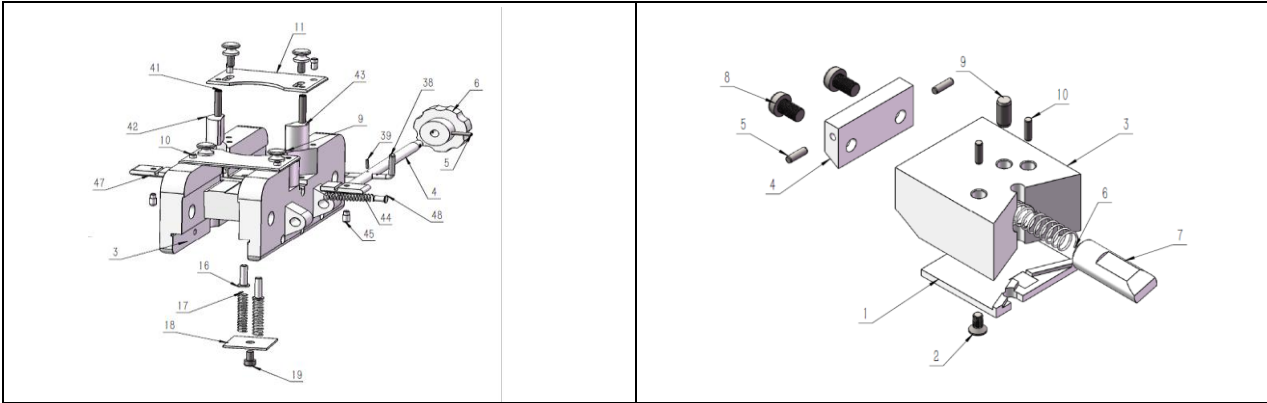

七、INSPECTION&PACKING

7.1.INSPECTION PICTURE



7.2. INSPETION REPORT

| Shineworld | | Supplier | Signature/Engineer/Date |
|---------------------|-------------|------------------------------------|-------------------------|
| | | Product Name and specification | 2019-11-28 |
| | | Order No. 0265, 785621912258 | |
| Inspection Standard | | | |
| S/N | ITEM | Inspection Specification | Inspection Result |
| 1 | SMT machine | SMT machine | OK |
| | | | OK |
| | SMT machine | SMT machine | OK |
| | | | OK |
| | | | OK |
| | | | OK |
| 2 | Box | 1. Size and quantity as list shows | OK |
| | | | OK |
| | | | OK |
| | | | OK |
| | | | OK |
| | | | OK |

| Shineworld | | Equipment inspection report | |
|---------------------|----------------------------|--|-------------------------|
| | | Supplier | Signature/Engineer/Date |
| | | Product Name 2 sets with welding machine PCB with die | 2020-03-25 |
| | | Order No. PCW 2019-10307 1908-2019-1031 | |
| Inspection Standard | | | |
| S/N | ITEM | Inspection Specification | Inspection Result |
| 1 | J2 COB welding machine | Copper wire: ø1.25-ø1.50mm Al wire: ø0.50-ø0.60mm | OK |
| 2 | J3 COB welding machine | Copper wire: ø0.5-ø1.2mm Al wire: ø0.50-ø0.60mm | OK |
| 3 | welding die | 0.95 | 2 PCS OK |
| 4 | 2 sets cob welding machine | 1.20 | 2 PCS OK |
| 5 | welding die | 1.50 | 2 PCS OK |
| 6 | PCB with die | 2.90 | 2 PCS OK |
| 7 | | | |
| 8 | | | |
| 9 | | | |
| 10 | | | |
| 11 | Box 1 | 380mm*230mm*430mm | 47KG |
| 12 | Box 2 | 390mm*430mm*479m | 47KG |
| 13 | Package | | |
| 14 | | | |
| 15 | | | |
| 16 | | | |
| 17 | Final report | The machine reach the FT requirements and is ready to shipment | |

7.3. PACKING

7.3.1.PACKING DETAILS

| SN | Name | HS code | Dimension(mm) | | | Unit | Unit net | Unit gross | PKG NO |
|----|----------------------------|---|---------------|-----|-----|--------------------|----------|------------|--------|
| | | | | | | V(M ³) | Weight | Weight | |
| 1 | SWJ4T Cold welding machine | 8468800000 | 550 | 550 | 920 | 0.01 | 130 | 130 | 1 |
| | 申报要素 | 1 品名：冷焊机 2 用途：用于电缆生产线 3 加工方式：用挤压的方式连接金属丝 4 品牌：无； 5 型号：无 | | | | | | | |

7.3.2. PACKIGN PITURE



SWMHD-1 multi-wire welding machine

一. Advantage:

| | |
|---|---|
|  | <ol style="list-style-type: none"> 1. Welding Results is perfect 2. Pulling force test: constant to the joints. 3. The resistance test: Resistance value is not greater than that of the original wire. 4. changes of wire diameter: In order to meet the user's need for welding the wires of various materials our company can provide the cold welding dies having various kind if inner grooves for users |
|---|---|



二. How to choose the model

2.1 Single wire

| Item | Model | Copper wire size | Aluminum wire size | Dimension | N.W | Die |
|-------------|----------|------------------|--------------------|---------------|-------|-----|
| | | (mm) | (mm) | (mm) | | |
| J1 Portable | SWM-J1 | Φ0.10~0.50 | Φ0.10~0.50 | 160x50x160 | 1Kg | J1 |
| J1 | SWMJ1T | Φ0.10~0.55 | Φ0.10~0.60 | 260x90x220mm | 3Kg | J1 |
| J2 | SWM-2T | Φ0.30-Φ1.20 | Φ0.30-Φ1.40 | 220x130x200 | 9.5Kg | J2 |
| J3 | SWM-3T | Φ1.00-Φ3.25 | Φ1.00-Φ5.00 | 300x180x300 | 36Kg | J3 |
| J4TY | SWM-4T | Φ1.00-Φ4.00 | Φ1.00-Φ6.00 | 550x550x920 | 130Kg | J4 |
| J5TY | SWM-J5TY | Φ4.00-Φ8.00 | Φ4.00- 14.00 | 1190x570x1100 | 650Kg | |

2.2 Multi Wire

| Item | Model | Wire size | Dimension | N.W | Die |
|------|---------|--|-----------------|-------|---------------------------|
| 1 | SWMHD-1 | 0.5 mm ² -10mm ² | 600x500x1200mm | 45KG | Quartz Glass Sleeve |
| 2 | SWMHD-2 | 16mm ² -120mm ² | 1260*660*1200mm | 150KG | Quartz Glass Sleeve |

三、Quotation

| | |
|----------------|----------------------|
| CUSTOMER CODE: | QUOTION NO: DATE: |
|----------------|----------------------|

| | |
|--|--|
| CUSTOMER INFORMATION: TEL: FAX: ATTN: | MANUFACTURE: PAYMENT TERMS:100 TT IN ADVANCE BENEFICIARY: SHANGHAI SHINEWORLD ENGINEERING CO., LTD. ACCOUNT NO.: 450773903470 (USD) BANK NAME: BANK OF CHINA, SHANGHAI DALIAN ROAD SUB-BRANCH BANK ADDRESS:NO. 688, DALIAN ROAD, YANGPU DISTRICT, SHANGHAI, CHINA BANK TEL.: 86-21-33772960 FAX: 86-21-33772962 SWIFT CODE: BKCHCNBJ300 |
|--|--|

| SN | DESCRIPTION | PICTURE | QTY | FOB SHANGHAI UNIT PRICE/USD | FOB SHANGHAI AMOUNT/USD |
|---------------|--|---|---------|-----------------------------|-------------------------|
| 1 | SWMHD-1 multi-wire welding machine 0.5 mm ² -10mm ² |  | 1.00SET | 5,000.00 | 5,000.00 |
| 2 | Quartz Glass Sleeve |  | 1.00SET | 0.5.00 | 0.5.00 |
| TOTAL: | | | | | |

REMARK:

- 1, The detailed specification will be integral part of this quotation.
- 2, Price basis: Price are for delivery FOB Shanghai, China according to INCOTERMS 2010. And the exchange rate for USD: RMB is 1:6.60. If the exchange rate is changed over 0.5%, the quotation will be adjusted accordingly even in the validity time.
- 3, Validity of quotation: the quotation is validly within 30 days after issue date.
- 4, Delivery period: the delivery time is 10 days after receipt of your down payment
- 5, the quotation is based china standard material and package.
- 10, All the bank charge is paid by buyer.

Leading the global wire and cable industry with intelligent manufacturing and new

materials.

四、SPECIFICATION

SWMHD-1 multi-wire welding machine



| Model | SWMHD-1 | SWMHD-2 |
|----------------|--|---------------------------------------|
| Welding range | 0.5 mm ² -10mm ² | 16mm ² -120mm ² |
| Voltage | 220V | 380V |
| Power | 3kva | 40kva |
| Multiple gears | 12 | 12 |
| Dimensions | 600*500*1200mm | 1260*660*1200mm |

| | | |
|-----|------|-------|
| G.W | 45kg | 150kg |
| N.W | 55kg | 150kg |

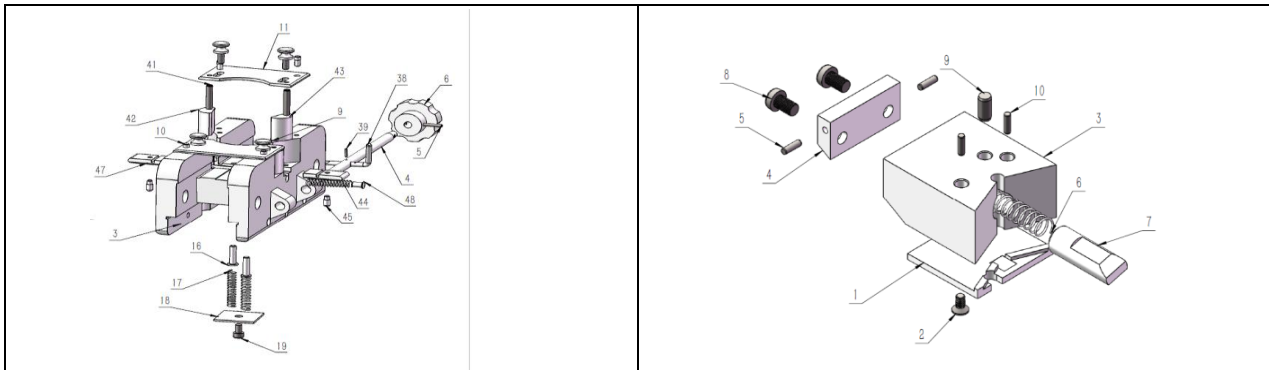
五、 SPARE PARTS
六、 ENGINEERING DOCUMENTS

七、 INSPECTION&PACKING
7.1.INSPECTION PICTURE

7.2. INSPETION REPORT

| | |
|--|--|
| | |
|--|--|

| Shineworld | | | | Supplier: _____ Signature: Engineer: _____ Product Name: _____ Order No: SWMHD-1/2018-10/01 | |
|------------|-------------|---|-------------------|---|------------|
| SN | ITEM | Inspection Standard | Inspection result | Photos | Conclusion |
| 1 | weld welder | 1 Model: CH-20 (4PCS) - CH-20 (2PCS) 2 QTY: 2PCS | OK |  | OK |
| | | 1 Model: SQ-10 2 QTY: 2PCS | OK |  | OK |
| 2 | box | 1 Size and quantity as per drawing | OK |  | OK |

| Shineworld | | | | Equipment inspection report | |
|------------|-----------------------------|---|-------------------|---|------------|
| SN | ITEM | Inspection Standard | Inspection result | Photos | Conclusion |
| 1 | J2 cold welding machine | Copper wire: φ0.25-φ1.50mm Al wire: φ0.30-φ1.80mm | OK |  | OK |
| 2 | J3 cold welding machine | Copper wire: φ0.30-φ1.80mm Al wire: φ0.30-φ1.80mm | OK | | OK |
| 3 | welding die | 0.80 | 2 PCS OK | | OK |
| 4 | 2 wire cold welding machine | welding die 1.50 | 2 PCS OK | | OK |
| 5 | welding die | 1.50 | 2 PCS OK | | OK |
| 6 | 4 PCS welding die | 2.80 | 2 PCS OK | | OK |
| 7 | | | | | |
| 8 | | | | | |
| 9 | | | | | |
| 10 | | | | | |
| 11 | box 1 | 380mm*230mm*420mm | 17KG |  | |
| 12 | box 2 | 380mm*430mm*470mm | 47KG | | |
| 13 | | | | | |
| 14 | Package | | | | |
| 15 | | | | | |
| 16 | | | | | |
| 17 | Final report | The machine reach the PI requirements and is ready for shipment | | | |

7.3. PACKING

7.3.1. PACKING DETAILS

| SN | Name | HS code | Dimension(mm) | | | Unit | Unit net | Unit gross | PKG NO |
|----|------------------------------------|---|---------------|-----|-----|--------------------|----------|------------|--------|
| | | | | | | V(M ³) | Weight | Weight | |
| 1 | SWMHD-1 multi-wire welding machine | 8468800000 | 600 | 500 | 120 | 0.01 | 198 | 220 | 1 |
| | 申报要素 | 1 品名：冷焊机 2 用途：用于电缆生产线 3 加工方式：用挤压的方式连接金属丝 4 品牌：无； 5 型号：无 | | | | | | | |

7.3.2. PACKING PICTURE



SWMHD-2 multi-wire welding machine

一. Advantage:

| | |
|--|---|
|  | <ol style="list-style-type: none"> 1. Welding Results is perfect 2. Pulling force test: constant to the joints. 3. The resistance test: Resistance value is not greater than that of the original wire. 4. changes of wire diameter: In order to meet the user's need for welding the wires of various materials our company can provide the cold welding dies having various kind if inner grooves for users |
|--|---|

二. How to choose the model
2.1 Single wire

| Item | Model | Copper wire size | Aluminum wire size | Dimension | N.W | Die |
|-------------|----------|------------------|--------------------|---------------|-------|-----|
| | | (mm) | (mm) | (mm) | | |
| J1 Portable | SWM-J1 | Φ0.10~0.50 | Φ0.10~0.50 | 160x50x160 | 1Kg | J1 |
| J1 | SWMJ1T | Φ0.10~0.55 | Φ0.10~0.60 | 260x90x220mm | 3Kg | J1 |
| J2 | SWM-2T | Φ0.30-Φ1.20 | Φ0.30-Φ1.40 | 220x130x200 | 9.5Kg | J2 |
| J3 | SWM-3T | Φ1.00-Φ3.25 | Φ1.00-Φ5.00 | 300x180x300 | 36Kg | J3 |
| J4TY | SWM-4T | Φ1.00-Φ4.00 | Φ1.00-Φ6.00 | 550x550x920 | 130Kg | J4 |
| J5TY | SWM-J5TY | Φ4.00-Φ8.00 | Φ4.00- 14.00 | 1190x570x1100 | 650Kg | |

2.2 Multi Wire

| Item | Model | Wire size | Dimension | N.W | Die |
|------|-------|-----------|-----------|-----|-----|
|------|-------|-----------|-----------|-----|-----|

| | | | | | |
|---|---------|--|-----------------|-------|---------------------------|
| 1 | SWMHD-1 | 0.5 mm ² -10mm ² | 600x500x1200mm | 45KG | Quartz Glass Sleeve |
| 2 | SWMHD-2 | 16mm ² -120mm ² | 1260*660*1200mm | 150KG | Quartz Glass Sleeve |

三、Quotation

| CUSTOMER CODE: | | QUOTION NO: | | | |
|-----------------------|--|---|---------|-----------------------------|-------------------------|
| | | DATE: | | | |
| CUSTOMER INFORMATION: | | MANUFACTURE: | | | |
| TEL: | | PAYMENT TERMS:100 TT IN ADVANCE | | | |
| FAX: | | BENEFICIARY: SHANGHAI SHINeworld ENGINEERING CO., LTD. | | | |
| ATTN: | | ACCOUNT NO.: 450773903470 (USD) | | | |
| | | BANK NAME: BANK OF CHINA, SHANGHAI DALIAN ROAD | | | |
| | | SUB-BRANCH | | | |
| | | BANK ADDRESS:NO. 688, DALIAN ROAD, YANGPU | | | |
| | | DISTRICT, SHANGHAI, CHINA | | | |
| | | BANK TEL.: 86-21-33772960 | | | |
| | | FAX: 86-21-33772962 SWIFT CODE: BKCHCNBJ300 | | | |
| SN | DESCRIPTION | PICTURE | QTY | FOB SHANGHAI UNIT PRICE/USD | FOB SHANGHAI AMOUNT/USD |
| 1 | SWMHD-2 multi-wire welding machine 0.5 mm ² -10mm ² |  | 1.00SET | 12000.00 | 12000.00 |
| 2 | Quartz Glass Sleeve |  | 1.00SET | 0.5.00 | 0.5.00 |
| TOTAL: | | | | | |

REMARK:

- 1, The detailed specification will be integral part of this quotation.
- 2, Price basis: Price are for delivery FOB Shanghai, China according to INCOTERMS 2010. And the exchange rate for USD: RMB is 1:6.60. If the exchange rate is changed over 0.5%, the quotation will be adjusted accordingly even in the validity time.
- 3, Validity of quotation: the quotation is validly within 30 days after issue date.
- 4, Delivery period: the delivery time is 10 days after receipt of your down payment
- 5, the quotation is based china standard material and package.
- 11, All the bank charge is paid by buyer.

Leading the global wire and cable industry with intelligent manufacturing and new materials.

四、SPECIFICATION

SWMHD-2 multi-wire welding machine



| Model | SWMHD-10 | SWMHD-20 |
|----------------|--|---|
| Welding range | CU:1.00 mm²-16mm² AL:2.00mm²-25.00mm² | CU:50 mm²-300mm² AL:50mm²-400mm² |
| Voltage | 220V | 380V |
| Power | 3kva | 40kva |
| Multiple gears | 12 | 12 |
| Dimensions | 600*500*1200mm | 1400*680*1820mm |
| G.W | 56 | 400 |
| N.W | 56 | 400 |

五、SPARE PARTS

六、ENGINEERING DOCUMENTS

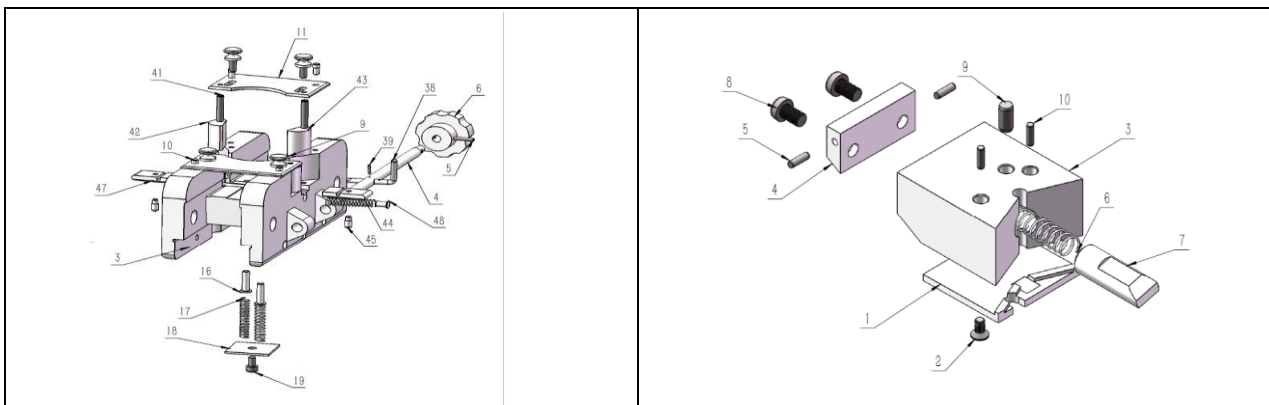































七、INSPECTION&PACKING

7.1.INSPECTION PICTURE



7.2. INSPETION REPORT

| Inspection Standard | | Inspection result | | Photos | | Conclusion | |
|---------------------|-------------|--|----|---|---|------------|--|
| 1 | cold welder | 1 Model: CH-20 (APCA) - CH-20 (27KW) 2 QTY: 2Pcs | OK |  |  | OK | |
| | cold welder | 1 Model: SD-10 2 QTY: 2Pcs | OK |  |  | OK | |
| 2 | box | 1 Size and quantity as per box | OK |  |  | OK | |

| Inspection Standard | | Inspection result | | Photos | | Conclusion | |
|---------------------|-------------------------|---|-------|---|---|------------|--|
| 1 | 22 cold welding machine | Copper wire: φ0.25-φ1.50mm | OK |  |  | OK | |
| 2 | 23 cold welding machine | Copper wire: φ0.25-φ2.0mm | OK |  |  | OK | |
| 3 | welding die | 1.20 | 2 PCS |  |  | OK | |
| 4 | welding die | 1.20 | 2 PCS |  |  | OK | |
| 5 | welding die | 1.50 | 2 PCS |  |  | OK | |
| 6 | welding die | 2.00 | 2 PCS |  |  | OK | |
| 11 | box 1 | 390mm*230mm*420mm | 17KG |  |  | | |
| 12 | box 2 | 390mm*420mm*470mm | 49KG |  |  | | |
| 13 | Package | | |  |  | | |
| 14 | | | |  |  | | |
| 15 | | | |  |  | | |
| 16 | | | |  |  | | |
| 17 | Final report | The machine reach the IT requirements and is ready to shipment. | | | | | |

7.3. PACKING

7.3.1.PACKING DETAILS

| SN | Name | HS code | Dimension(mm) | | | Unit | Unit net | Unit gross | PKG NO |
|----|----------------------------|---|---------------|-----|------|-------|----------|------------|--------|
| | | | | | | V(M³) | Weight | Weight | |
| 1 | SWJ4T Cold welding machine | 8468800000 | 1260 | 660 | 1200 | 0.01 | 150 | 150 | 1 |
| | 申报要素 | 1 品名：冷焊机 2 用途：用于电缆生产线 3 加工方式：用挤压的方式连接金属丝 4 品牌：无； 5 型号：无 | | | | | | | |

7.3.2. PACKING PICTURE

